

Brass Ball Valve

2 Piece • Full Port • Male x Solder Connection • 600 WOG

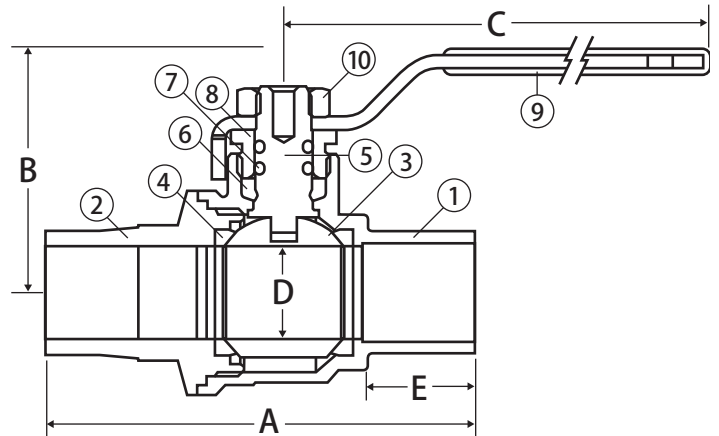

H100MS



Material Specifications

| No. | Part | Material |
|-----|-----------------|------------------------------|
| 1 | Body | Brass - CW617N |
| 2 | End Connection | Brass - CW617N |
| 3 | Ball | Chrome Plated Brass - CW617N |
| 4 | Seat (2) | Hostaflon® TFM 1600 |
| 5 | Stem | Brass - CW614N |
| 6 | Packing | Hostaflon® TFM 1600 |
| 7 | Stem O-ring (2) | Viton® |
| 8 | Packing Gland | Brass - CW614N |
| 9 | Handle | Steel - Geomet® Plated |
| 10 | Handle Nut | Steel - Geomet® Plated |

Features

- Blow-out proof stem
- Triple sealing stem with 2 Viton® o-rings and Teflon® seal
- 100% leak tested
- 100% Made in Italy
- Leakproof stem - Lifetime Warranty
- 29 in-Hg vacuum rating

Approvals

- MSS SP-110
- ANSI B1.20.1
- ASME/ANSI B16.18

Valve Seat Rating

1/4" - 3/4" 600 WOG, 1" - 2" 500 WOG - 150 WSP

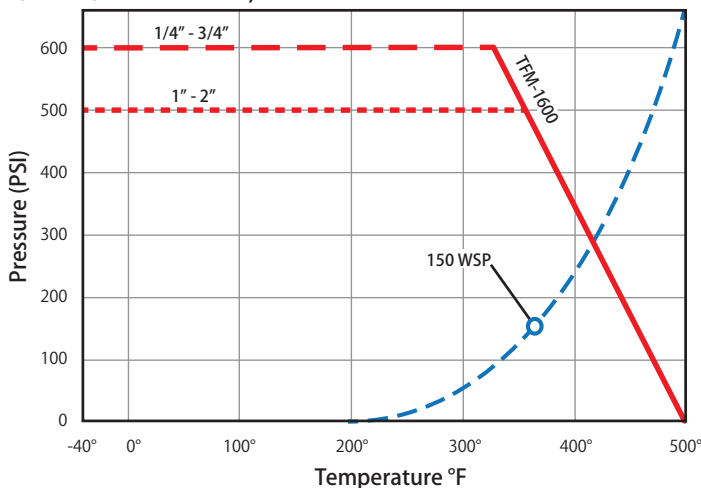

Dimensions

| Part No. | Size | A | B | C | D | E | Cv |
|----------|------|------|------|------|------|------|-------|
| H100-613 | 1/2" | 2.76 | 1.53 | 2.95 | 0.59 | 0.51 | 16.82 |
| H100-614 | 3/4" | 3.37 | 1.95 | 3.74 | 0.79 | 0.76 | 34.80 |
| H100-615 | 1" | 4.02 | 2.40 | 4.75 | 0.97 | 0.92 | 52.20 |